

TORUS[®]

WATERTUBE

CONDENSING COMMERCIAL BOILERS & WATER HEATERS

1250 – 4000 MBH





Condensing Commercial Boilers & Water Heaters

Torus® watertube boilers and water heaters bring next level performance in a small compact footprint to today's applications.

The RBI tradition of high quality, performance equipment in a user-friendly design continues with Torus.

Incorporating all industry-proven components including HeatNet 3.0 touchscreen cascade control, Tru-Flow fuel/air coupling system with 10:1 turndown and capacities to 4000 MBH Torus has the solution for all commercial installations.

The Torus uses a pressure driven mixing system with no moving parts to provide a reliable 10:1 turndown, without lowering the CO₂% while avoiding nuisance ignition lockouts.



Features and Benefits

- 1250 – 4000 MBH
- Up to 97.5% AHRI Certified Boiler Efficiency
- Full Modulation (10:1 water heater / 10:1 boiler)
- 4 Pass Double-Row Watertube Heat Exchanger (160 psi/ ASME (H & HLW) Stamp)
- 316L Stainless Steel
- Variable Volume, Full Flow and Primary/Secondary
- Sika Vortex Flow Sensor
- HeatNet 3.0 Integrated Control Platform
- Touchscreen Programming and Diagnostics
- Modbus, LonWorks and BACnet BMS Integration
- Low NO_x and CO
- Easy Maintenance and Installation
- Category II and IV (up to 160')
- PVC/CPVC, Polypropylene and Stainless Steel Vent Approved
- Warranty (Heat Exchanger): 10-year Boiler; 5-year Water Heater
- NG/LP/Dual Fuel
- Outdoor Installation
- Top Inlet/Outlet Water Connections (Optional with Indoor Models Only)



Torus heat exchangers are designed for optimum performance and durability. Made from an industrial quality 316L stainless steel Torus heat exchangers are reliable and robust while being very resistant to both thermal shock and acidic condensate.

A unique 4-pass design works in concert with a new multi-channel manifold and increased tube diameters resulting in ultra-high efficiency with very low pressure drop.

Torus heat exchangers are manufactured with an industrial quality 316L stainless steel through a process called tube hydroforming. Tube hydroforming allows the shaping of stainless steel tubes that are not only stronger and lighter but also have a higher quality surface than competitive heat exchangers maximizing both performance and durability in a compact design.

Hydroforming insures a uniform and consistent gap between the tubes facilitating consistent exhaust gas circulation and uniform heat transfer throughout the entire heat exchanger.

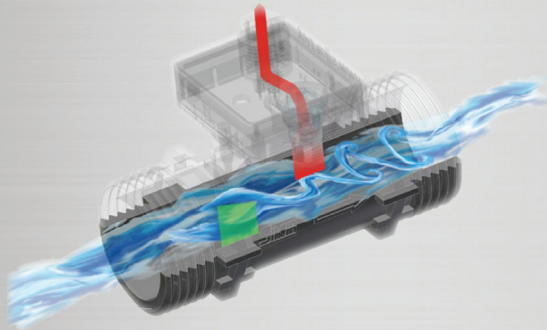
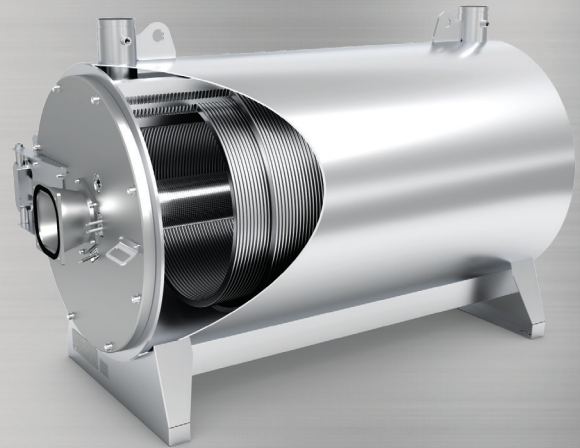

All Torus Series boilers include a SIKA vortex flow sensor mounted in a by-pass configuration and mapped to indicate the boiler flow in (gpm). The SIKA flow sensor utilizes vortex technology which is then converted to an electrical signal sent directly to the HeatNet Boiler Management System for real time flow annunciation. The SIKA flow sensor is fully adjustable throughout the boiler model operating range.



Ease of Service

Torus just may be the easiest piece of equipment ever to service. A unique burner door system provides easy access to both the burner and heat exchanger tube bundle. All burner doors come with a slide and hinge mechanism that easily slides outwards offering full access to the combustion chamber for annual inspection and service.

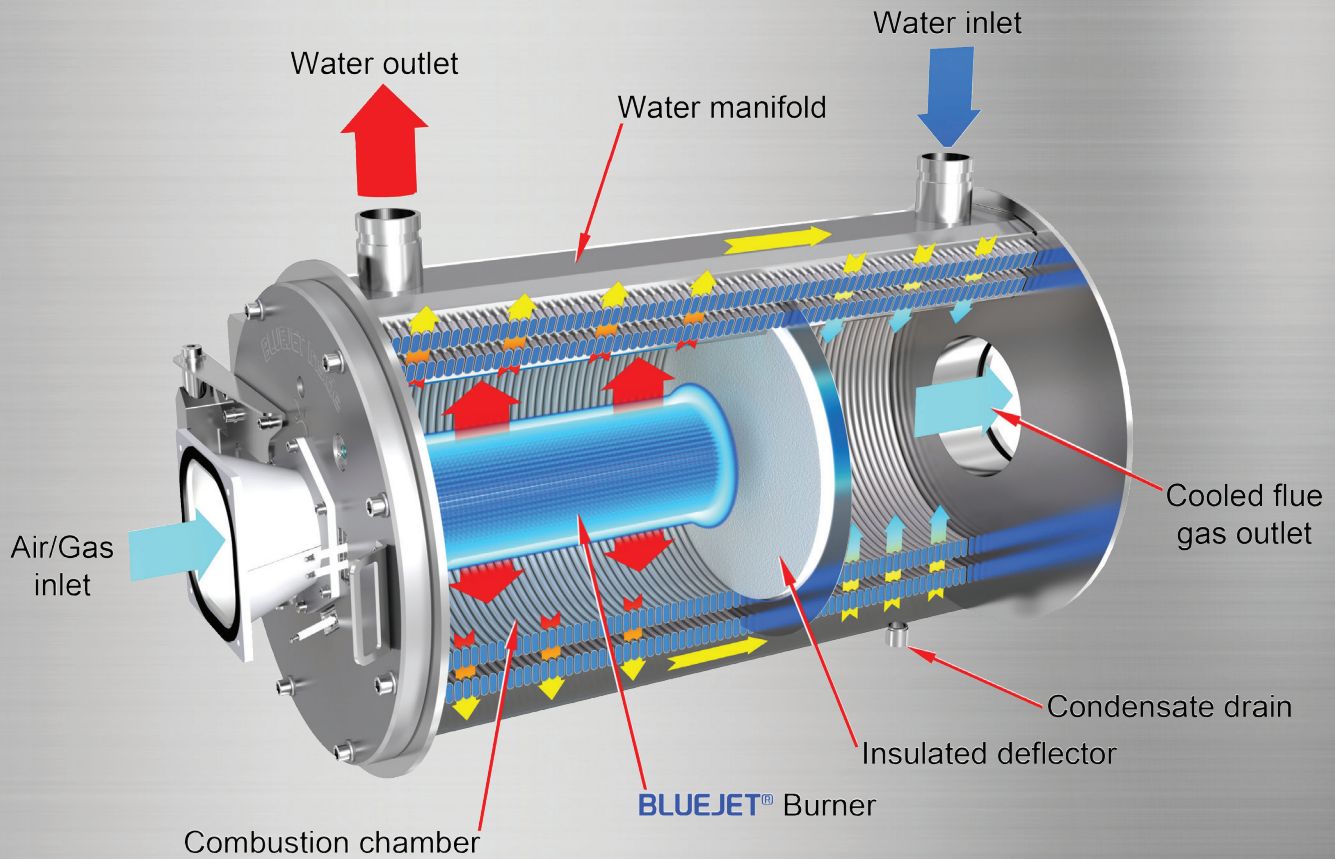

Torus' Bluejet® burner offers industry leading modulation capacity, flame retention and combustion quality. Whether natural gas or LP gas, BlueJet's low NOx design works in perfect concert with our Tru-Flow fuel/air system providing consistent reliable operation.

4-Pass Watertube Heat Exchanger

Torus heat exchangers use a 4-pass system for maximum efficiency. The unique path of water throughout the heat exchanger is designed to absorb as much heat energy as possible.

Pass 1: Return water passes through the first set of inner tubes absorbing residual heat energy.

Pass 2: Water passes through the exhaust gas chamber

Pass 3: Outer tubes of the combustion chamber

Pass 4: Supply water distribution final pass through the inner tubes of the combustion chamber

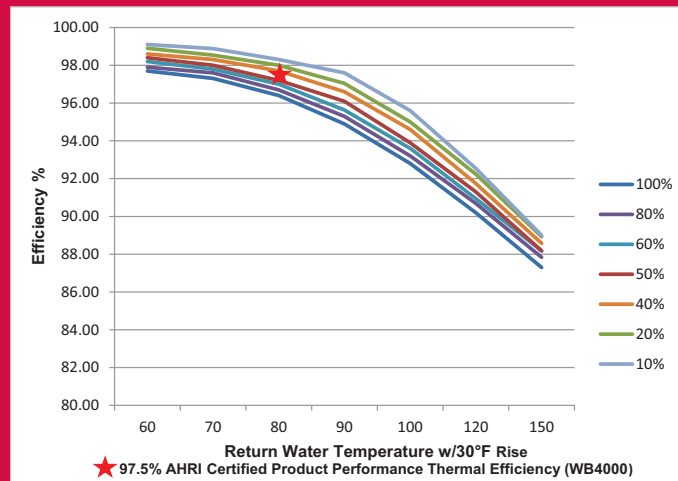

TORUS® (WB/WW) Product Summary

1250-4000

WATERTUBE

| | 1250 | 1500 | 2000 | 2500 | 3000 | 4000 |
|---|-------------|-------------|--------------|--------------|--------------|--------------|
| Ratings and Capacities | | | | | | |
| Input BTU/HR - (WB/WW) | 1,250,000 | 1,500,000 | 1,999,000 | 2,500,000 | 3,000,000 | 4,000,000 |
| Output BTU/HR - Boiler - (WB) | 1,206,250 | 1,447,500 | 1,929,035 | 2,437,500 | 2,925,000 | 3,900,000 |
| AHRI Thermal Efficiency - Boiler (%) | 96.5 | 96.5 | 96.5 | 97.5 | 97.5 | 97.5 |
| Water Heater Hourly Recovery Capacity (GPH @ 60 deg f) | 2426 | 2911 | 3880 | 4852 | 5882 | 7843 |
| Water Heater Hourly Recovery Capacity (GPH @ 100 deg f) | 1456 | 1747 | 2328 | 2911 | 3529 | 4706 |
| Water Heater Hourly Recovery Capacity (GPH @ 140 deg f) | 1040 | 1248 | 1663 | 2079 | 2521 | 3361 |
| Turn Down (Boiler) (WB) | 10:1 | 10:1 | 10:1 | 10:1 | 10:1 | 10:1 |
| Turn Down (Water Heater) (WW) | 10:1 | 10:1 | 10:1 | 10:1 | 10:1 | 10:1 |
| HP - Boiler | 36.04 | 43.25 | 57.66 | 72.45 | 87.39 | 116.52 |
| Fuel Type | NG/LP | NG/LP | NG/LP | NG/LP | NG/LP | NG/LP |
| Category | CAT II/IV | CAT II/IV | CAT II/IV | CAT II/IV | CAT II/IV | CAT II/IV |
| Water Volume (gal) | 11 | 13 | 16.9 | 24.9 | 24.9 | 41.3 |
| Design Data - (Max working Press - psig) | 160 | 160 | 160 | 160 | 160 | 160 |
| Min water pressure (psi) | 20 | 20 | 20 | 20 | 20 | 20 |
| ASME Sect IV Fireside Htg Surface (sq-ft) | 100.17 | 119.8 | 153.19 | 300.69 | 300.69 | 402.93 |
| ASME Sect IV Waterside Htg Surface (sq-ft) | 92.93 | 111.08 | 141.93 | 277.23 | 277.23 | 371.25 |
| Electrical (Standard) | 120V-1ph | 120V-1ph | 230V-1ph | 230V-3ph | 230V-3ph | 230V-3ph |
| Electrical (Optional - 3ph) | N/A | N/A | 208-575V-3ph | 208-575V-3ph | 208-575V-3ph | 208-575V-3ph |
| FLA (amps) | 17.14 | 21.0 | 25.6 | 15.05 | 15.05 | 19.9 |
| Min. Gas Pressure (w.c.) N/G | 4 | 4 | 4 | 4 | 4 | 4 |
| Min. Gas Pressure (w.c.) LP | 8 | 8 | 8 | 8 | 8 | 8 |
| Max. Gas Pressure (w.c.) | 14 | 14 | 14 | 14 | 14 | 14 |
| Max Vent (Equiv. ft) | 80/160 | 80/160 | 160 | 160 | 160 | 160 |
| Max Combustion Air (Equiv. ft) | 80/160 | 80/160 | 160 | 160 | 160 | 160 |
| Trim | | | | | | |
| Number of Relief Valves | 1 | 1 | 1 | 1 | 1 | 1 |
| Relief Valve Pressure Rating (PSI) (WB/WW) | 50/125 | 50/125 | 50/125 | 50/125 | 50/125 | 50/125 |
| Inlet Water Connection (in) | 2 1/2 | 2 1/2 | 2 1/2 | 4 | 4 | 4 |
| Outlet Water Connection (in) | 2 1/2 | 2 1/2 | 2 1/2 | 4 | 4 | 4 |
| Gas Connection (in) | 1 1/2 | 1 1/2 | 1 1/2 | 1 1/2 | 1 1/2 | 2 |
| Vent Outlet Connection (in) | 6/8 | 6/8 | 8 | 10 | 10 | 12 |
| Standard Vent Material | SS | SS | SS | SS | SS | SS |
| Optional Non Metallic Vent Material | PVC/CPVC/PP | PVC/CPVC/PP | PVC/CPVC/PP | PVC/CPVC/PP | PVC/CPVC/PP | PVC/CPVC/PP |
| Combustion Air Connection | 8 | 8 | 8 | 10 | 10 | 12 |
| Dimensions | | | | | | |
| Height (in) | 63 5/16 | 63 5/16 | 63 3/8 | 77 27/32 | 77 27/32 | 77 27/32 |
| Width (in) | 32 9/16 | 32 9/16 | 32 9/16 | 44 1/16 | 44 1/16 | 44 1/16 |
| Depth (in) | 63 3/8 | 68 | 76 | 87 7/32 | 87 7/32 | 96 |
| Operating Weight (lbs.) | 1084 | 1183 | 1388 | 2311 | 2311 | 2866 |
| Shipping Weight (lbs.) | 1112 | 1220 | 1406 | 2460 | 2460 | 2983 |
| Clearance Service/Combustible | | | | | | |
| Front (in) | 36/6 | 36/6 | 36/6 | 36/6 | 36/6 | 36/6 |
| Rear (in) | 24/6 | 24/6 | 24/6 | 24/6 | 24/6 | 24/6 |
| Right Side (in) | 24/6 | 24/6 | 24/6 | 24/6 | 24/6 | 24/6 |
| Left Side (in) | 24/6 | 24/6 | 24/6 | 24/6 | 24/6 | 24/6 |
| Top (in) | 30/6 | 30/6 | 30/6 | 30/6 | 30/6 | 30/6 |

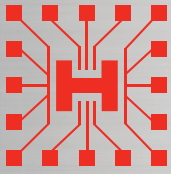

HEATNET[®] 3.0

Every premium efficiency boiler manufactured by the Mestek Boiler Group is integrated with HeatNet 3.0[®] – an innovative, digital Boiler Management System that provides consistency and feedback through digital communication. By continuously monitoring several system characteristics, HeatNet 3.0 modulates boiler firing rates to maximize turndown ratios and maintain peak efficiency – no matter the load.

HeatNet 3.0 doesn't just benefit stand-alone boilers; it is a valuable and cost-saving tool in operating a multi-boiler Master/Member network of up to 16 boilers, including mixed-size units. By functioning as a boiler management system, HeatNet 3.0 can incorporate a mixture of condensing boilers and non-condensing boilers to eliminate costly third-party, wall-mounted boiler control platforms.

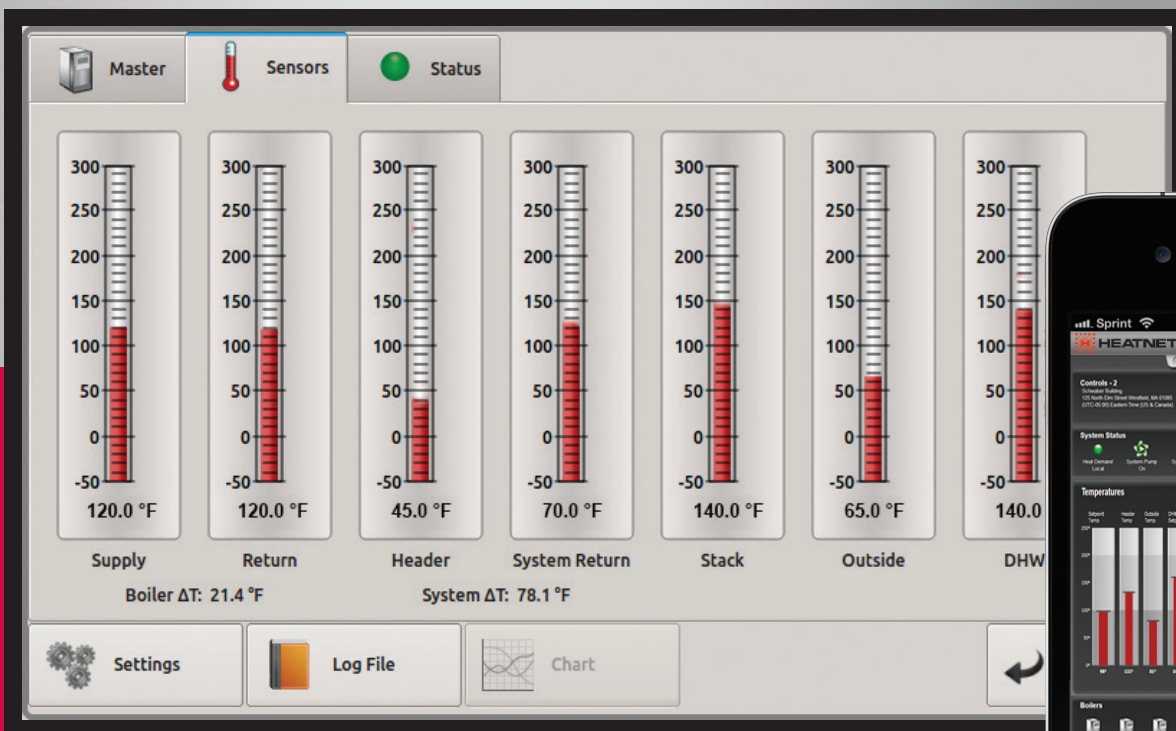

HEATNET[®] 3.0

- Digital Touch Screen Programming
- Lead/Lag Cascade (16 Units)
- Mixed-Size Unit Communication
- Adaptive Modulation
- Circular Pump/VFD/Valve Control
- BMS Integration
- Freeze Protection & Delta T Monitoring
- Hybrid/base Load Capability
- Priority Boiler Control
- Domestic Hot Water Communication
- Web-Based Remote Monitoring/Dashboard
- Diagnostics and Troubleshooting
- Set Points
- Exclusive Remote Monitoring Capability with HeatNet Online

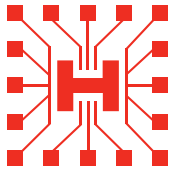

HEATNET[®] 3.0

HeatNet Online: Remote Monitoring, Boiler Performance Control & System Protection

HeatNet Online allows for real-time remote monitoring of boiler temperatures, limit circuit inputs, diagnostics and overall system performance.

HeatNet Online is a completely secure web-based monitoring program that allows visual boiler feedback from anywhere through an easy-to-read dashboard. View boiler set points, service logs and system issues from your office computer, tablet or cell phone.

HeatNet Online sends email text alerts for out-of-specification operation allowing for proactive responses to potentially harmful situations protecting the equipment and your investment.

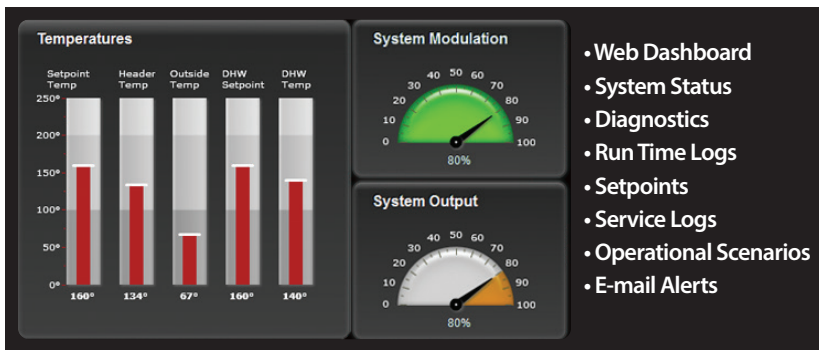

Building Dashboard

- Supports Multiple Systems
- "Live" Data Updated Every 60 Seconds
- Setpoint, Header, DHW Set, DHW (if enabled) Stack (if detected)
- System Modulation, System Output
- Visual Cues for Firing Boilers

System History

- Visual Trending
 - Header Temp
 - Modulation
 - DHW Temp
 - Setpoints (Operating, DHW)
- "Zoom" Charting Scales from Hour to Minute Interval
- Log Entries
 - Full Log Event
 - Event Description
 - System Detail
 - No 1000 Log Limit

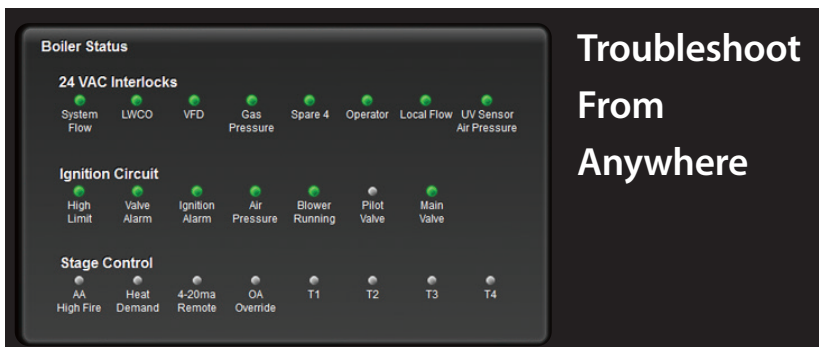
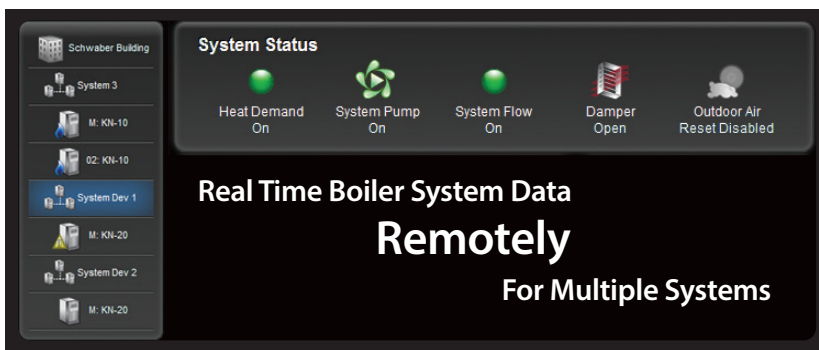

Service Log History

- Individual Entries Can Be Stand Alone or Attached to Warnings, Faults
- File Upload
 - Allows Technicians to Upload Pictures From Phone
- Dynamic Link
 - Links to Product Specific Support Literature



260 North Elm Street, Westfield, MA 01085

Tel. (413) 564-5515

7555 Tranmere Drive, Mississauga, Ontario L5S 1L4

Tel. (905) 670-5888

www.rbiwaterheaters.com

